



DSD-16RS050 DC SPUR GEAR MOTOR

典型应用/Typical applications :

自动快锁门、装订机、自动电视架、点钞机、聚光灯、卫生纸机、办公设备、家用电器、自动执行机构

Auto shutter, binding machine, automatic TV rack, money counter, spot light, tissue machine, office equipments, household appliances, automatic actuator

DRAWING (MM)

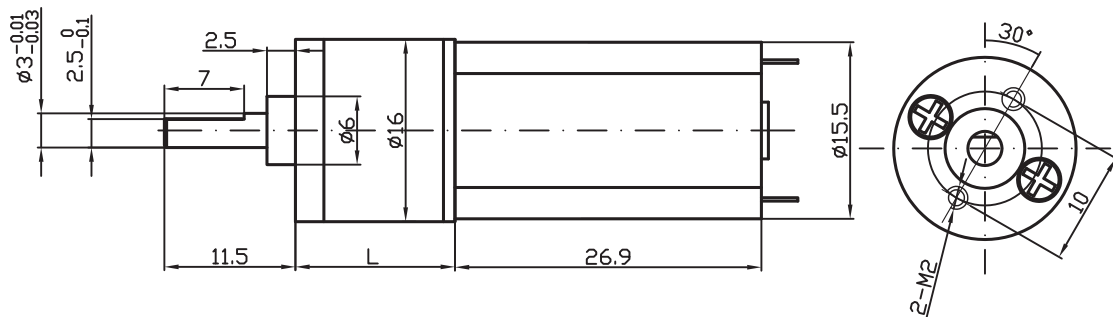

齿轮箱参数/GEARBOX DATA:

级数 Reduction stage	3	4	5	6	7
减速比 Reduction ratio	10K, 14K	23K, 28K 32K, 40K	46K, 56K, 65K 79K, 91K, 112K	130K, 159K, 183K 224K, 257K, 315K	365K, 448K, 515K 631K, 725K, 889K
齿轮箱长度 Gearbox length "L" mm	11	12.5	14	15.5	17
齿轮箱效率 Gearbox efficiency	73%	65%	59%	53%	48%

电机参数/MOTOR DATA:

电机型号 Motor model	额定电压 Rated voltage	空载/No load		负载/Load				堵转/Stall	
		电流	转速	电流	转速	扭矩	功率	扭矩	电流
		Current	Speed	Current	Speed	Torque	Output	Torque	Current
	V	mA	rpm	mA	rpm	gf. cm	W	gf. cm	mA
DSD-0500068000	6	≤65	8000	≤200	6500	7.5	0.50	≥36	≥500
DSD-05000612000	6	≤75	12000	≤300	9300	10	0.97	≥40	≥1000
DSD-0500098000	9	≤50	8000	≤150	6500	7	0.47	≥33	≥360
DSD-0500128000	12	≤35	8000	≤110	6500	6.5	0.44	≥31	≥170
DSD-05001217900	12	≤68	17900	≤300	12800	12	1.58	≥54	≥1260

电机参数谨供参考, 请以实际样板为准。

The motor data are for reference only, real samples may be with different specifications.

齿轮箱电机输出扭矩: 电机输出扭矩 x 减速比 x 齿轮箱效率; 齿轮箱电机输出转速: 电机输出转速 / 减速比。

Output torque of gear motor: output torque of motor x reduction ratio x gearbox efficiency;

Output speed of gear motor: output speed of motor / reduction ratio.