

(Encoders) ME-28

- 双向霍尔作用译码器
Two Channel Hall Effect Encoder
- ★ 使用相对湿度: 20%~85%RH
Operating relative humidity
- ★ 使用温度范围: -40°C~+85°C
Operating temperature range



APPEARANCE SIZE



接口:
JST PHR-6
P=2.0-6P

Two Channel Encoder
Connections :

1. MOTOR-
2. MOTOR+
3. HALL SENSOR Vcc
4. HALL SENSOR GND
5. HALL SENSOR A Vout
6. HALL SENSOR B Vout

- *此译码器主要安装在RS-385、395电机上。
- *The encoder mainly install on the Motor of RS-385、395
- *每周输出3PPR, 7PPR, 12PPR, 13PPR
- *Each turn output 3PPR,7PPR,12PPR,13PPR

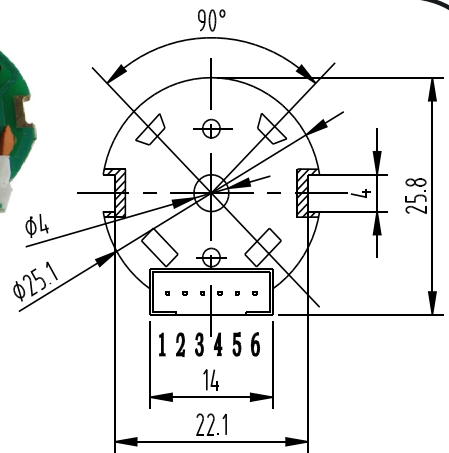

ELECTRICAL CHARACTERISTICS

At $V_s=4.5V$ to $24V$ with $20mA$ load with $T_a=-40^{\circ}C$ to $125^{\circ}C$ [$-40^{\circ}F$ to $257^{\circ}F$] unless otherwise noted.

规格特性 CHARACTERISTICS	代号 SYMBOL	测试条件 TEST CONDITIONS	极小 MIN	基本 REF	最大 MAX	UNITS
输入电压 Supply Voltage	Vcc	---	4.5	--	24	V
输入电流 Supply Current	Icc	---	--	14	20	mA
输出电流 Output Current	Ic	Vce=12V; Gauss<-170	--	~<0.1	20	mA
输出漏电流 Output Leakage Current	Icex	Output open;25°C[77°F]	--	--	10	μA
输出上升时间 Output Rise Time	Tr	RL=820Ω; CL=20pF;25°C	--	0.5	1.5	μS
输出下降时间 Output Fall Time	Tf	RL=820Ω; CL=20pF;25°C	--	0.2	1.5	μS

**输出电路
Output Circuit**

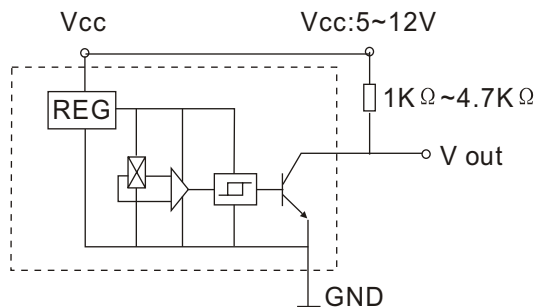

**输出波形
Output Wave**

